

NOTE:
 R151 = 2K7 FOR 12V MODULE
 R151 = 3K3 FOR 24V MODULE
 R151 = 4K7 FOR 48V MODULE

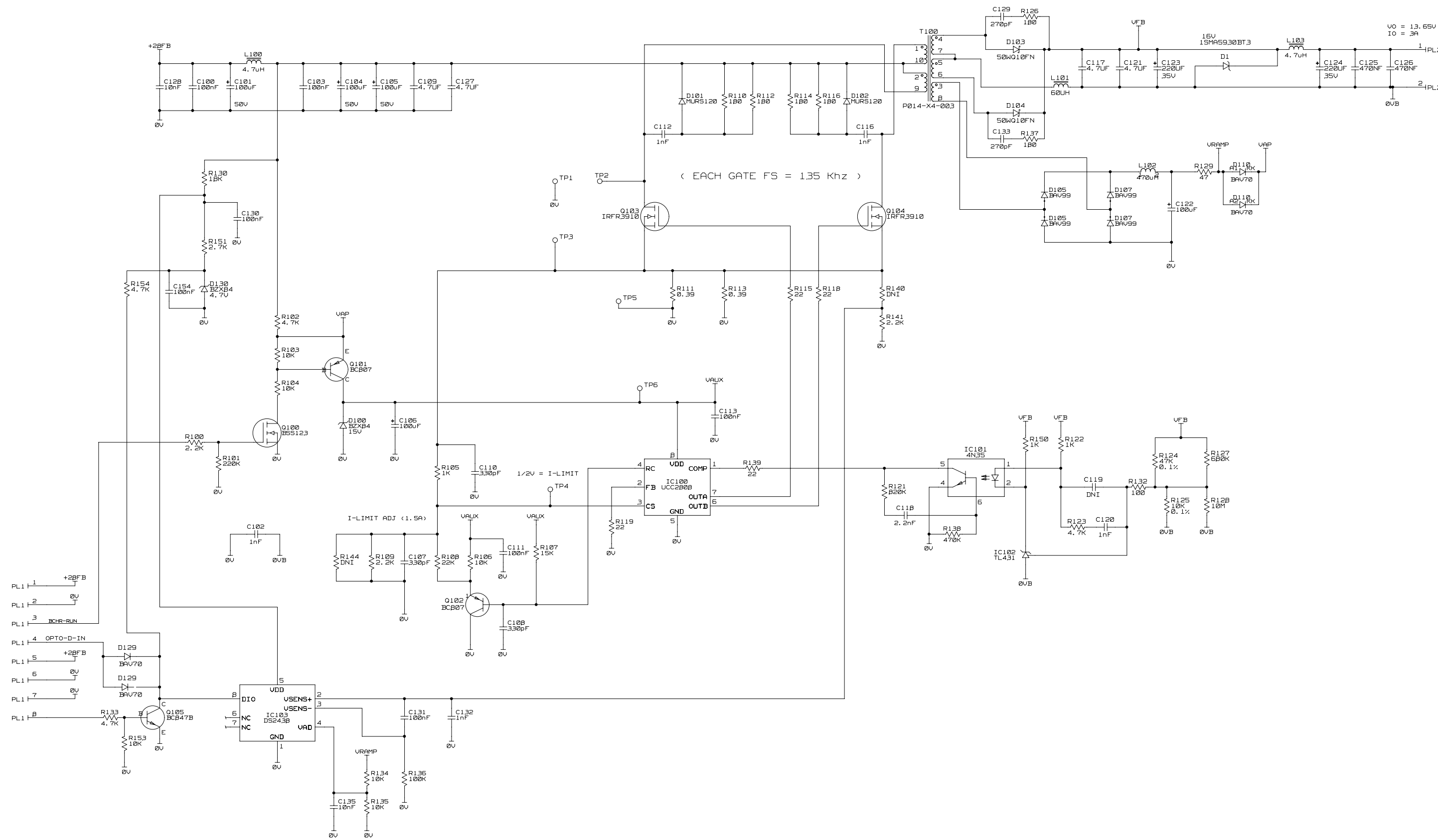

06A	ECC. 10120556	TB	SH	?	RVDC	26-04-03
05A	12V PROTOTYPE CLONED FROM 24V	TB	RVDC	?	RVDC	10-01-03
REV/ISS	AMENDMENTS	DRAWN	CHKD	D. O.	APVD	DATE

© TAIT ELECTRONICS		A1
TB8000		
PMU DC-DC 40W AUX PS 12V		
IPN:	ISSUE:	VARIANT NUMBER:
220-02020-06	A	?
FILE DATE: Mon Jun 27 11:08:26 2005		
ENGINEER:	FILE NAME:	SHEET NUMBER:
R Van Der Cloff	220_02020	1 OF 1